

Position	Qty.	Description	Single Price
	1	<p>MQ 3-35 Product No.: 96440336</p> <p>Complete system The MQ is a complete, all-in-one unit, incorporating pump, motor, diaphragm tank, pressure and flow sensor, controller and non-return valve. The controller ensures that the pump starts automatically when water is consumed and stops automatically when the consumption ceases. In addition, the controller protects the pump in case of faults.</p> <p>Installation Due to its compact design, the pump does not take up much space and is easy to install. No space around the pump is required.</p> <p>Simple operation The pump features a user-friendly control panel with ON/OFF button and indicator lights for indication of the operational state of the pump.</p> <p>Self-priming pump As it is self-priming, the MQ is able to pump water from a level below the pump. Provided it is filled with water, the pump is able to lift water from a depth of 8 m in less than 5 minutes. This facilitates installation and start-up of the pump and provides more reliable water supply in installations where there is a risk of dry running and leakages in suction hose or pipes.</p> <p>Built-in protective functions If exposed to dry running or excessive temperature, for example in case of seizure or overload, the pump will stop automatically, thus preventing a motor burnout.</p> <p>Automatic reset The pump features an automatic reset function. In case of dry running or similar alarm, the pump will stop. Restarting will be attempted every 30 minutes for a period of 24 hours. The reset function can be deactivated.</p> <p>Low noise level Thanks to its hydraulic design and internal cooling, the pump is extremely low-noise, which makes it suitable for indoor as well as outdoor use.</p> <p>Pressure tank The built-in pressure tank reduces the number of starts and stops in case of leakages in the pipe system, causing less wear on the pump.</p> <p>Maintenance No maintenance of the pump is required.</p> <p>Liquid: Liquid temperature range: 0 .. 35 °C</p> <p>Technical: Rated flow: 3 m³/h Rated head: 22 m Type of shaft seal: BVBP Approvals on nameplate: CE Curve tolerance: ISO 9906 Annex A</p> <p>Materials: Material, pump housing: POM + 25% glass fibre Material, impeller: PPO + 20% glass fibre-PTFE</p> <p>Installation: Range of ambient temperature: 0 .. 45 °C Maximum operating pressure: 7.5 bar Size, pipe connection: G 1</p> <p>Electrical data: Power input (P1): 850 W Mains frequency: 50 Hz Rated voltage: 1 x 220-240 V Rated current: 4 A</p>	Price on request

Position	Qty.	Description	Single Price
		Enclosure class (IEC 34-5): IP54 Insulation class (IEC 85): B Length of cable: 2 m Type of cable plug: SCHUKO	
		Others: Net weight: 13 kg Gross weight: 15.5 kg Shipping volume: 0.055 m ³	

Position	Qty.	Description	Single Price
	1	<p>MQ 3-35</p>  <p>Note! Product picture may differ from actual product</p> <p>Product No.: 96440336</p> <p>Complete system The MQ is a complete, all-in-one unit, incorporating pump, motor, diaphragm tank, pressure and flow sensor, controller and non-return valve. The controller ensures that the pump starts automatically when water is consumed and stops automatically when the consumption ceases. In addition, the controller protects the pump in case of faults.</p> <p>Installation Due to its compact design, the pump does not take up much space and is easy to install. No space around the pump is required.</p> <p>Simple operation The pump features a user-friendly control panel with ON/OFF button and indicator lights for indication of the operational state of the pump.</p> <p>Self-priming pump As it is self-priming, the MQ is able to pump water from a level below the pump. Provided it is filled with water, the pump is able to lift water from a depth of 8 m in less than 5 minutes. This facilitates installation and start-up of the pump and provides more reliable water supply in installations where there is a risk of dry running and leakages in suction hose or pipes.</p> <p>Built-in protective functions If exposed to dry running or excessive temperature, for example in case of seizure or overload, the pump will stop automatically, thus preventing a motor burnout.</p> <p>Automatic reset The pump features an automatic reset function. In case of dry running or similar alarm, the pump will stop. Restarting will be attempted every 30 minutes for a period of 24 hours. The reset function can be deactivated.</p> <p>Low noise level Thanks to its hydraulic design and internal cooling, the pump is extremely low-noise, which makes it suitable for indoor as well as outdoor use.</p> <p>Pressure tank The built-in pressure tank reduces the number of starts and stops in case of leakages in the pipe system, causing less wear on the pump.</p> <p>Maintenance No maintenance of the pump is required.</p> <p>Liquid: Liquid temperature range: 0 .. 35 °C</p> <p>Technical: Rated flow: 3 m³/h Rated head: 22 m Type of shaft seal: BVBP Approvals on nameplate: CE Curve tolerance: ISO 9906 Annex A</p> <p>Materials: Material, pump housing: POM + 25% glass fibre</p>	Price on request

Position	Qty.	Description	Single Price
		<p>Material, impeller: PPO + 20% glass fibre-PTFE</p> <p>Installation: Range of ambient temperature: 0 .. 45 °C Maximum operating pressure: 7.5 bar Size, pipe connection: G 1</p> <p>Electrical data: Power input (P1): 850 W Mains frequency: 50 Hz Rated voltage: 1 x 220-240 V Rated current: 4 A Enclosure class (IEC 34-5): IP54 Insulation class (IEC 85): B Length of cable: 2 m Type of cable plug: SCHUKO</p> <p>Others: Net weight: 13 kg Gross weight: 15.5 kg Shipping volume: 0.055 m³</p>	

Description	Value
Product name:	MQ 3-35 A-O-A BVBP
Product No:	96440336
EAN number:	5700393992177
Technical:	
Rated flow:	3 m ³ /h
Rated head:	22 m
Head max:	35 m
Type of shaft seal:	BVBP
Approvals on nameplate:	CE
Curve tolerance:	ISO 9906 Annex A
Pump version:	A
Model:	A
Materials:	
Material, pump housing:	POM + 25% glass fibre
Material, impeller:	PPO + 20% glass fibre-PTFE
Material code:	A
Installation:	
Range of ambient temperature:	0 .. 45 °C
Maximum operating pressure:	7.5 bar
Connect code:	O
Size, pipe connection:	G 1
Liquid:	
Liquid temperature range:	0 .. 35 °C
Electrical data:	
Power input (P1):	850 W
Mains frequency:	50 Hz
Rated voltage:	1 x 220-240 V
Rated current:	4 A
Enclosure class (IEC 34-5):	IP54
Insulation class (IEC 85):	B
Length of cable:	2 m
Type of cable plug:	SCHUKO
Controls:	
Switch:	on/off switch included
Others:	
Net weight:	13 kg
Gross weight:	15.5 kg
Shipping volume:	0.055 m ³

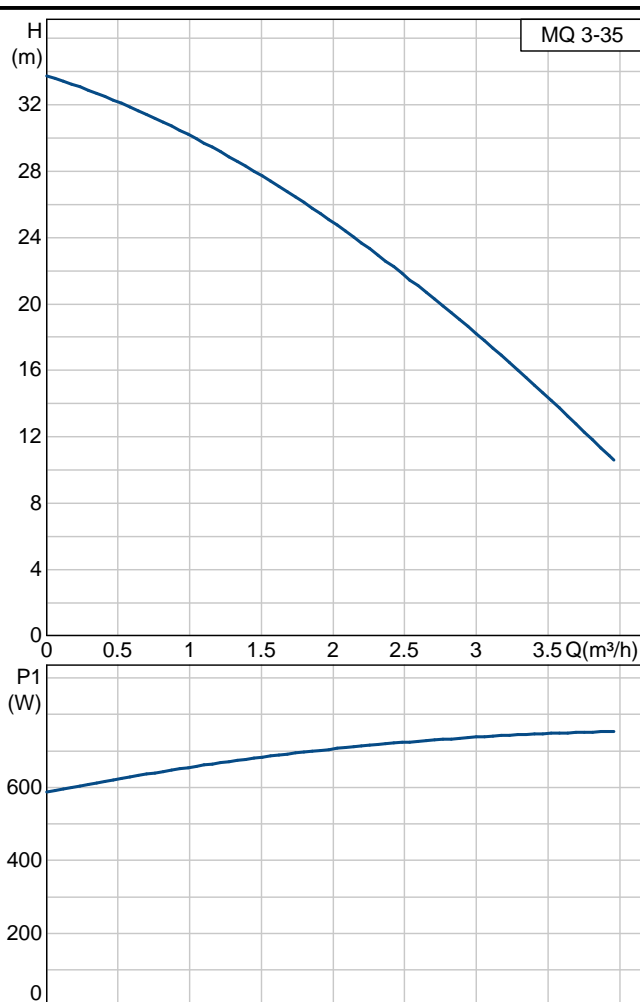

96440336 MQ 3-35

MQ 3-35

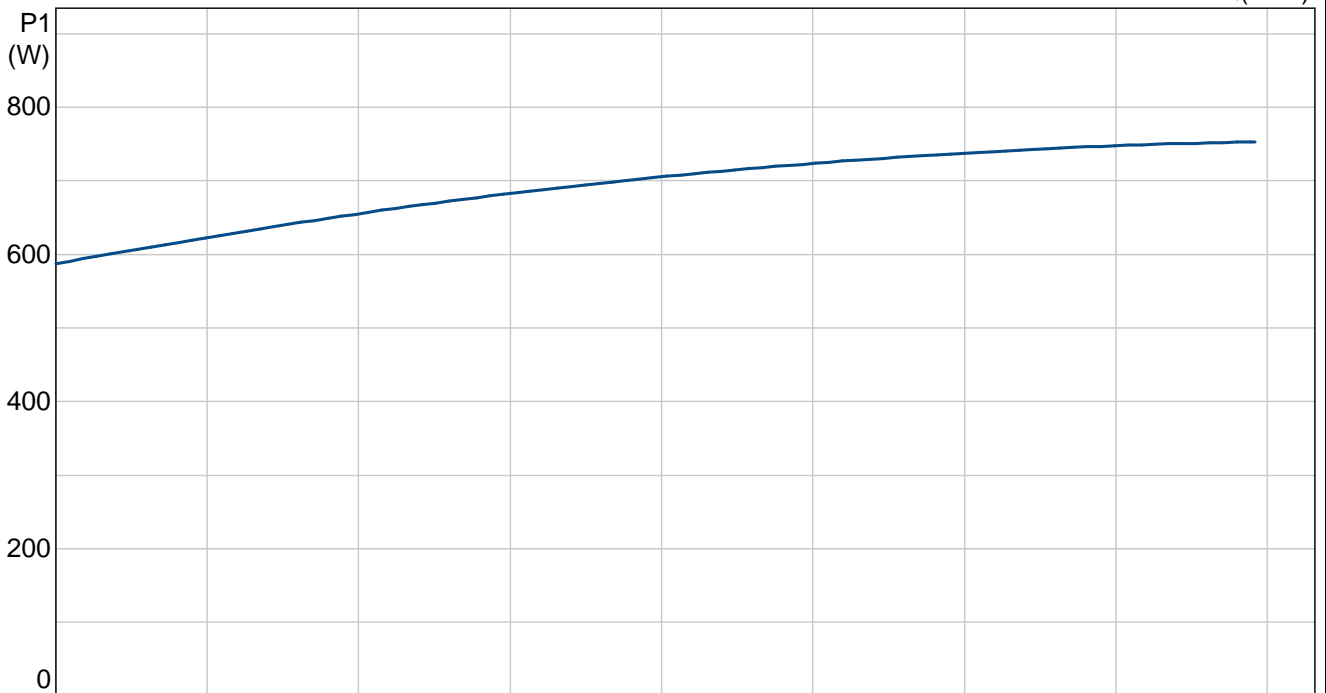
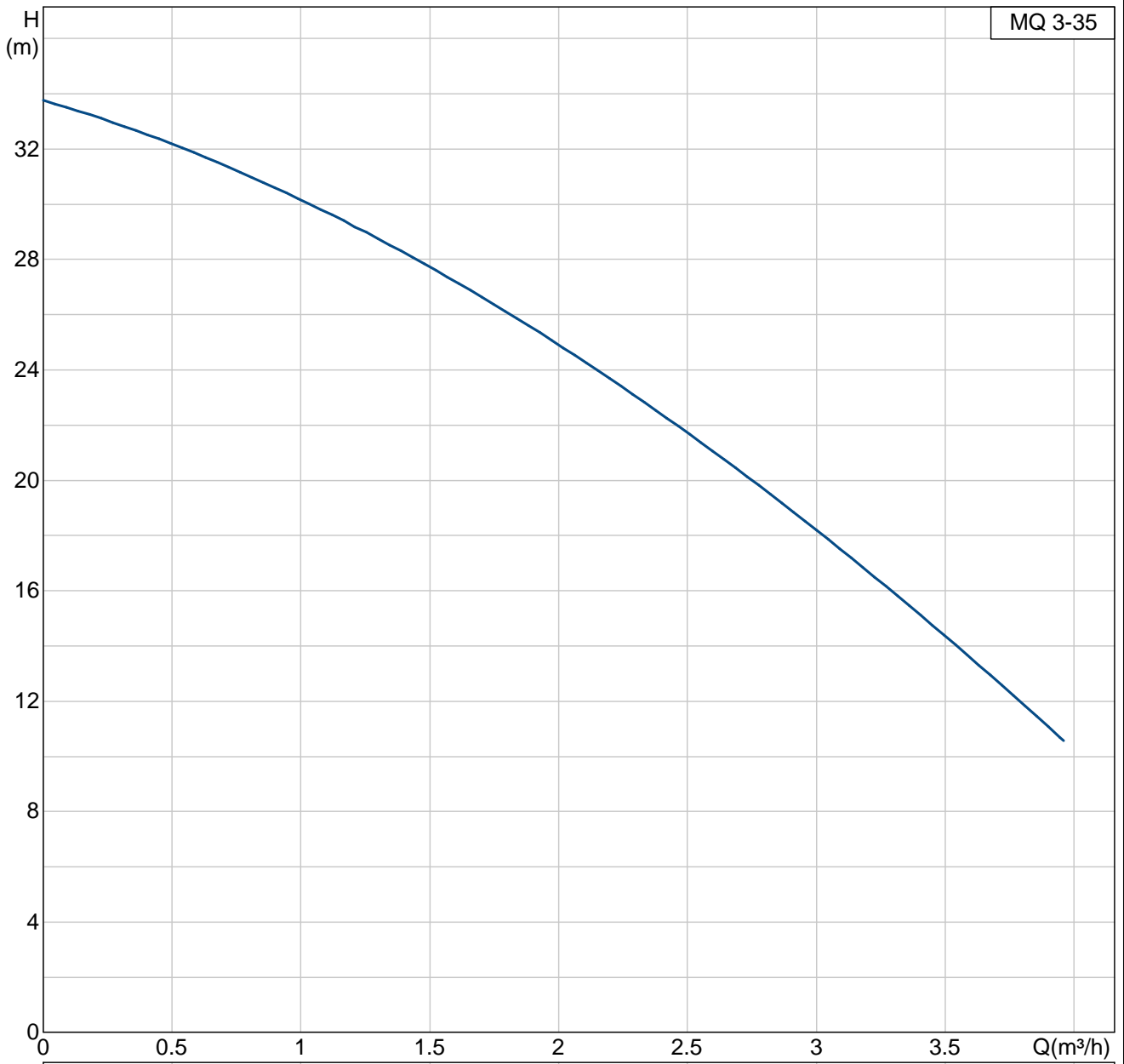

96440336 MQ 3-35

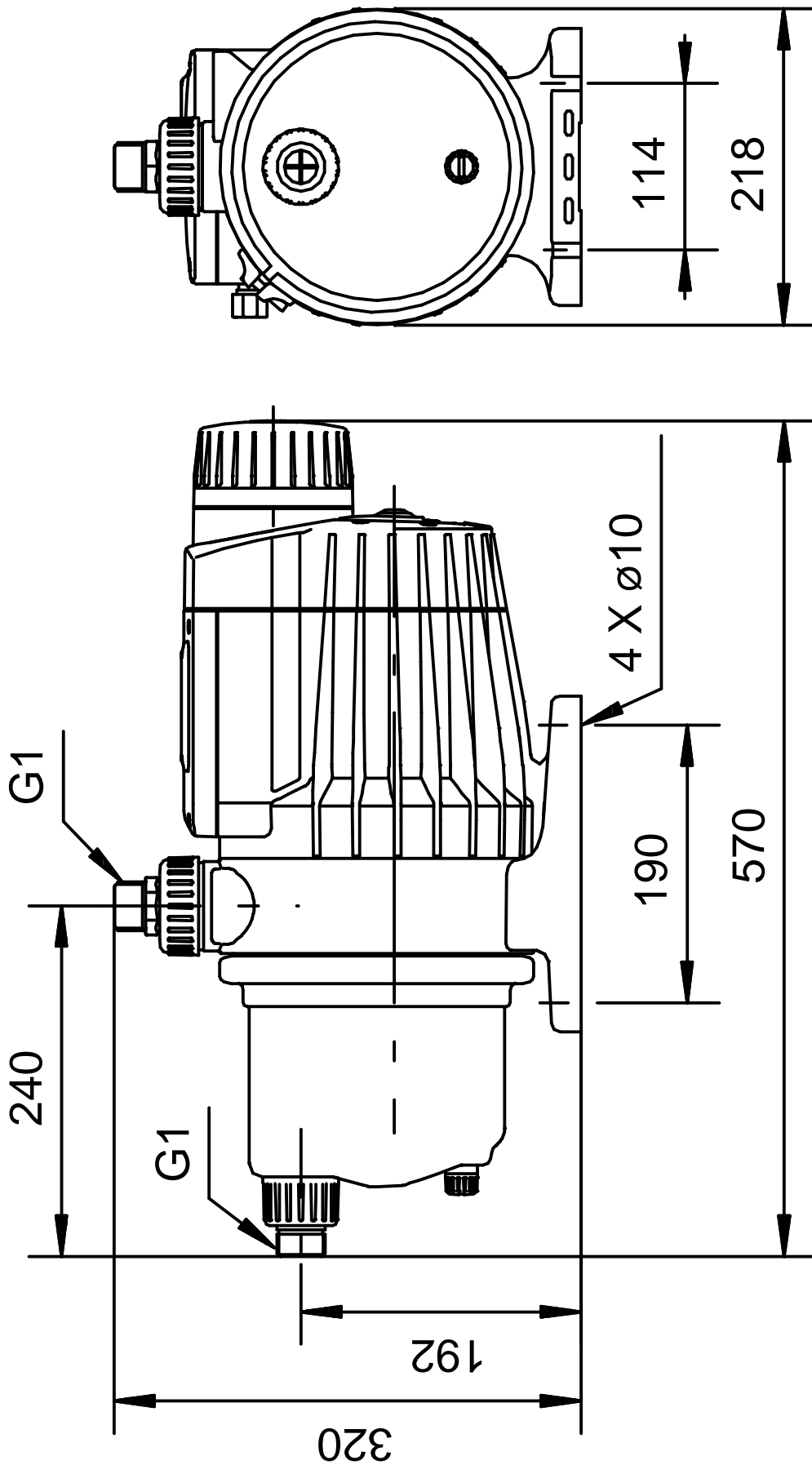

Note! All units are in [mm] unless others are stated.

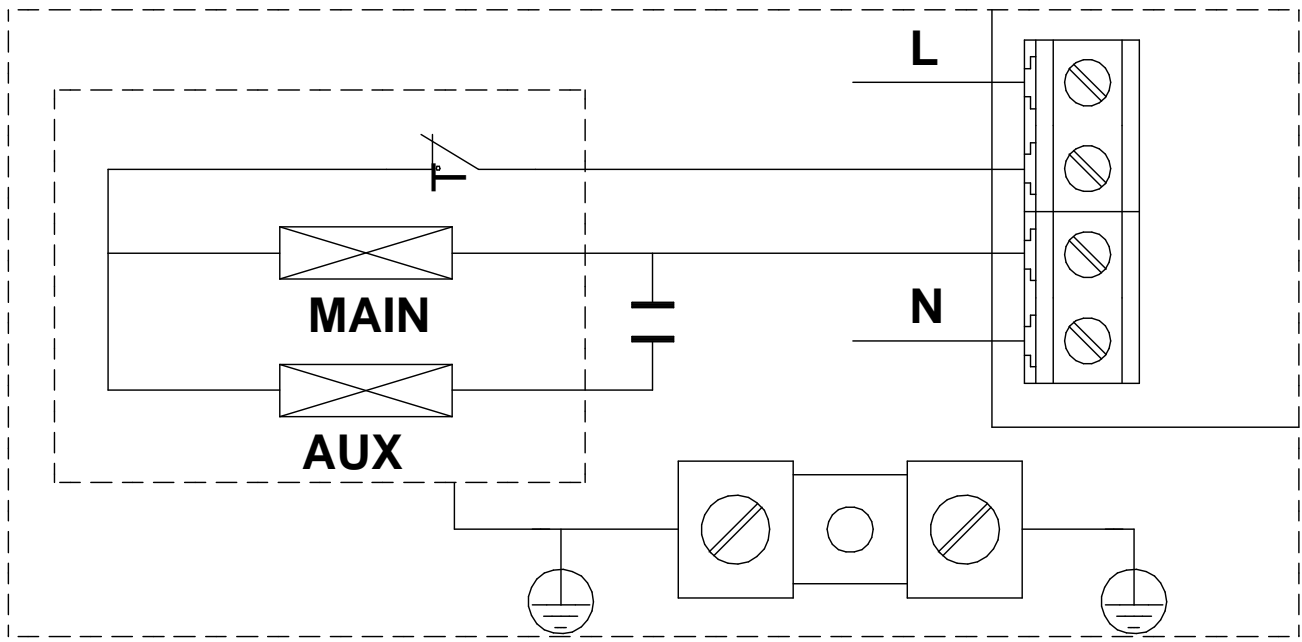

Note! All units are in [mm] unless others are stated.